



Cambridge International Examinations
Cambridge International General Certificate of Secondary Education

CANDIDATE
NAME

CENTRE
NUMBER

--	--	--	--	--

CANDIDATE
NUMBER

--	--	--	--



COMBINED SCIENCE

0653/31

Paper 3 (Core)

May/June 2017

1 hour 15 minutes

Candidates answer on the Question Paper.

No Additional Materials are required.

READ THESE INSTRUCTIONS FIRST

Write your Centre number, candidate number and name on all the work you hand in.

Write in dark blue or black pen.

You may use an HB pencil for any diagrams or graphs.

Do not use staples, paper clips, glue or correction fluid.

DO NOT WRITE IN ANY BARCODES.

Answer **all** questions.

Electronic calculators may be used.

You may lose marks if you do not show your working or if you do not use appropriate units.

A copy of the Periodic Table is printed on page 20.

At the end of the examination, fasten all your work securely together.

The number of marks is given in brackets [] at the end of each question or part question.

This document consists of **20** printed pages.

- 1 (a) Use lines to connect the box on the left to different boxes on the right to make correct sentences.

One is done for you. The sentence reads 'Flowering plants can respond to light and gravity'.

Draw **three** more lines to make three more correct sentences.

Flowering plants	produce haploid pollen.
	need oxygen for germination of seeds.
	lose water from leaves by perspiration.
	transport sugar through the xylem.
	can respond to light and gravity.
	need oxygen for photosynthesis.
	have root hair cells for water uptake.

[3]

- (b) Fig. 1.1 shows vertical sections of two different flowers. They are both pollinated by insects.

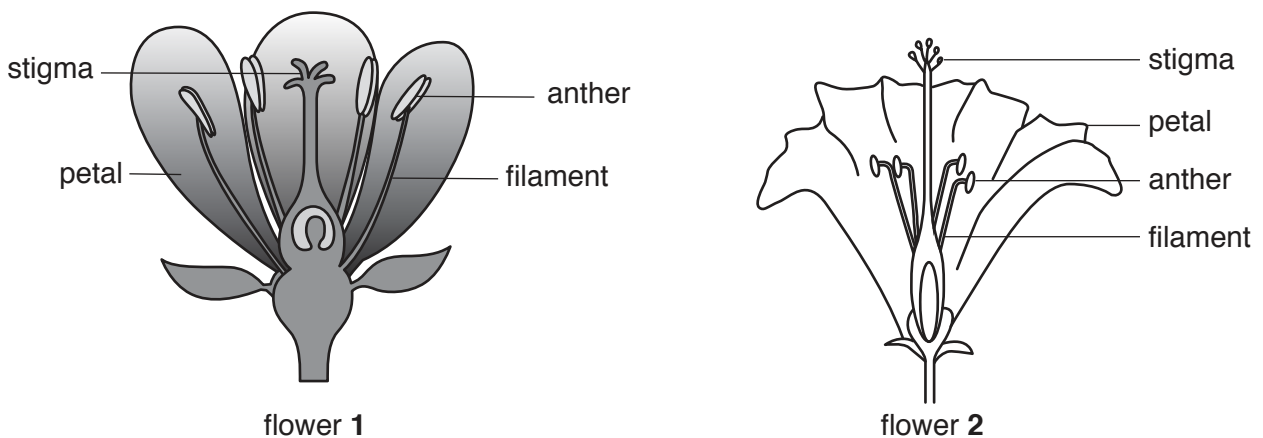

Fig. 1.1

(i) Suggest **two** features which the flowers in Fig. 1.1 might have that would help the flowers to attract insects.

1.

2.

[2]

(ii) Describe the differences in the arrangement of the male reproductive organs of flower 1 and of flower 2 as shown in Fig. 1.1.

.....

.....

..... [1]

(c) Pollen can go from the anther to the stigma in the same flower without needing insects. This is called self-pollination.

Suggest which flower in Fig. 1.1 would have less chance of self-pollination.

Explain your answer.

Flower because

.....

.....

[1]

- 2 (a) A molecule of methane contains one carbon atom bonded to four hydrogen atoms.

This bonding, shown in Fig. 2.1, involves shared pairs of electrons.

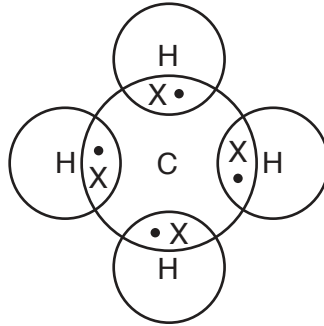

Fig. 2.1

- (i) State the type of chemical bonding shown in Fig. 2.1.

..... [1]

- (ii) State the type of elements that bond together by sharing pairs of electrons.

..... [1]

- (b) (i) During complete combustion, methane forms two gases.

Complete the **word** equation to show this reaction.

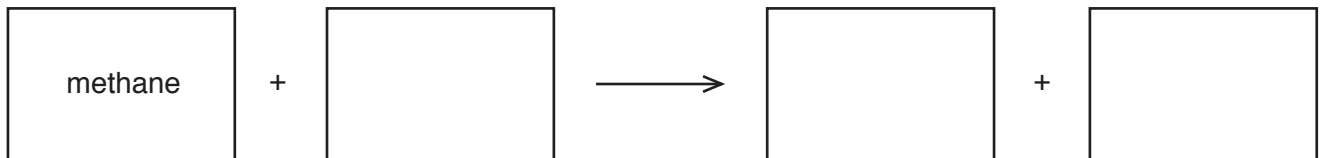

[2]

- (ii) Explain, in terms of energy changes, why methane is used as a fuel.

.....
 [1]

- (c) Methane is the main constituent of one fossil fuel.

- (i) State the name of this fossil fuel.

..... [1]

(ii) State the names of **two other** fossil fuels.

..... and [1]

(d) Refinery gas, gasoline and diesel oil are separated from a mixture of hydrocarbons by an industrial process.

(i) Name this industrial process.

..... [1]

(ii) State **one** use for bottled refinery gas.

..... [1]

- 3 Fig. 3.1 shows a wind surfer on a surf board, driven by the wind, sailing at a constant speed across the sea. The arrows labelled **A**, **B**, **C** and **D** show the forces acting on the surf board.

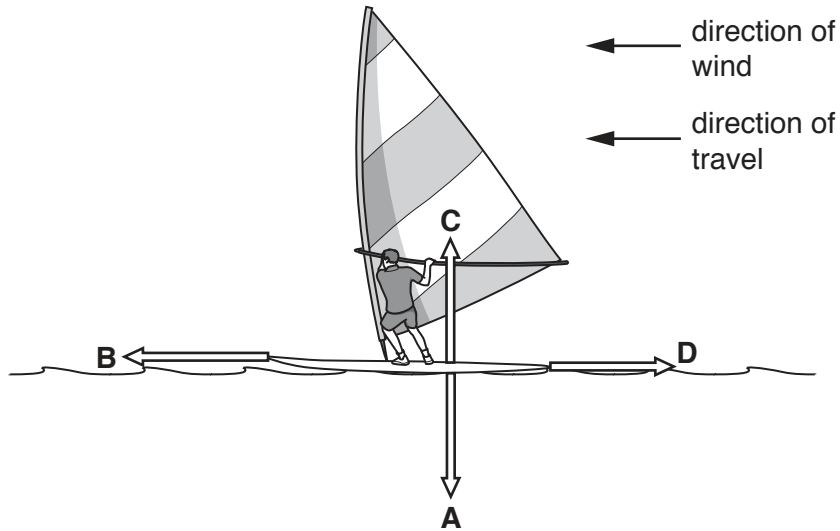

Fig. 3.1

- (a) (i) Complete Table 3.1 using the letters **A**, **B**, **C** and **D**.

Table 3.1

name of force	letter on Fig. 3.1
driving force	
frictional force	
upthrust of water	
weight	

[2]

- (ii) Force **A** is measured and found to be 1200 N.

State whether force **C** is 1200 N or has a different value.

Give a reason for your answer.

.....
 [1]

- (iii) State which force needs to be increased to make the surf board sail at a faster speed.

..... [1]

- (b) The speed of the surf board is 12km/h.

Calculate the speed of the surf board in m/s.

Show your working.

speed = m/s [1]

- (c) The wind provides the energy for the work needed to move the surf board across the sea.

- (i) State the two quantities that must be measured to calculate the work done in moving the surf board during its journey across the sea.

..... and [2]

- (ii) State the type of energy the surf board has when it is being moved by the wind.

..... [1]

- (iii) The wind stops blowing and the surf board slows down and stops.

Describe what has happened to the energy in (c)(ii).

.....
 [1]

4 (a) Define the terms

herbivore,

.....

carnivore.

.....

[2]

(b) Fig. 4.1 shows an aquatic food web. Phytoplankton are microscopic plants that float on the surface of the water. Zooplankton are very small animals.

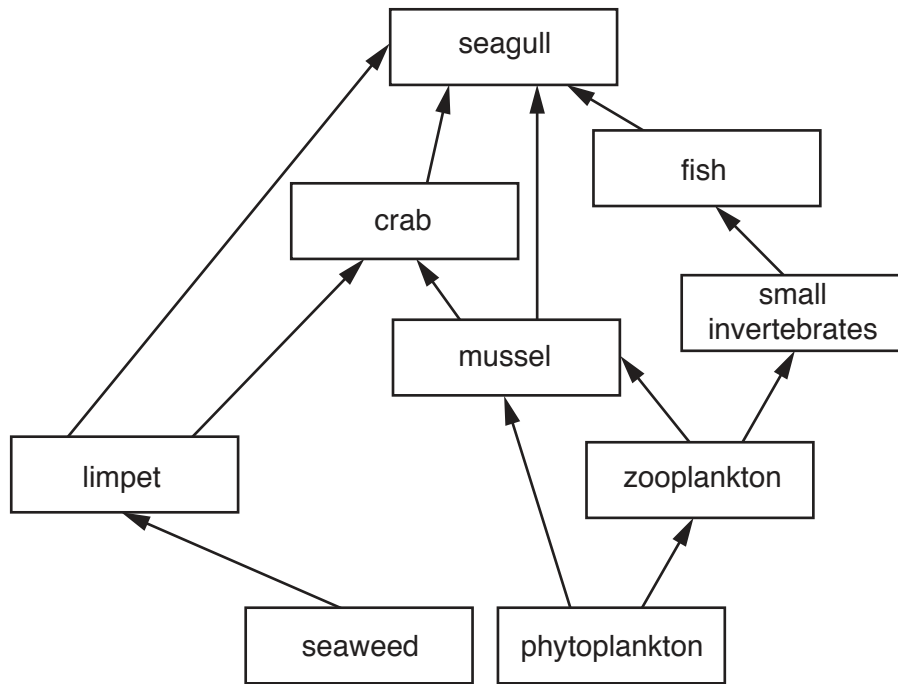

Fig. 4.1

(i) State **two** environmental conditions that can affect the rate of photosynthesis of the plants in the water.

1.
 2.

[2]

(ii) Using Fig. 4.1 draw **one** food chain which includes the crab.

[2]

(iii) The population of crabs decreases. Suggest how this can cause the number of mussels to increase,

.....
.....

to decrease.

.....
.....
.....

[3]

- 5 A student investigates the reaction between dilute sulfuric acid and copper(II) carbonate powder. The apparatus she uses is shown in Fig. 5.1.

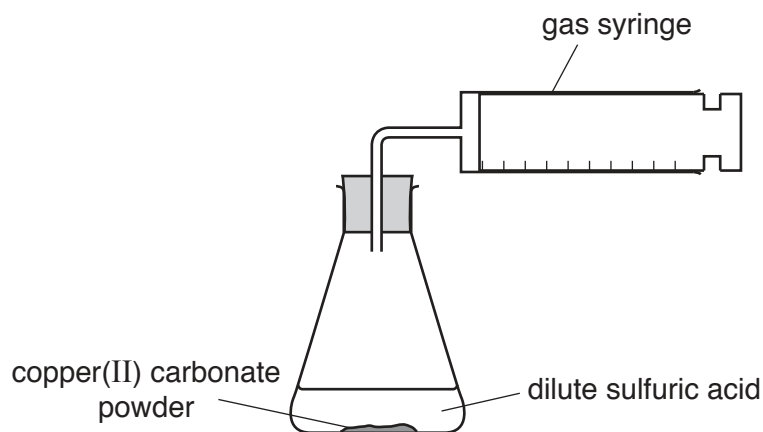

Fig. 5.1

The reaction produces a gas which is collected in the gas syringe.

- (a) (i) Name the gas and the salt which are produced in this reaction.

gas

salt

[2]

- (ii) Describe the pH change, if any, of the reaction mixture.

Name this type of reaction.

pH change

reaction type

[2]

- (b) The student records the volume of gas in the syringe for 10 minutes.

Her results are shown in Fig. 5.2.

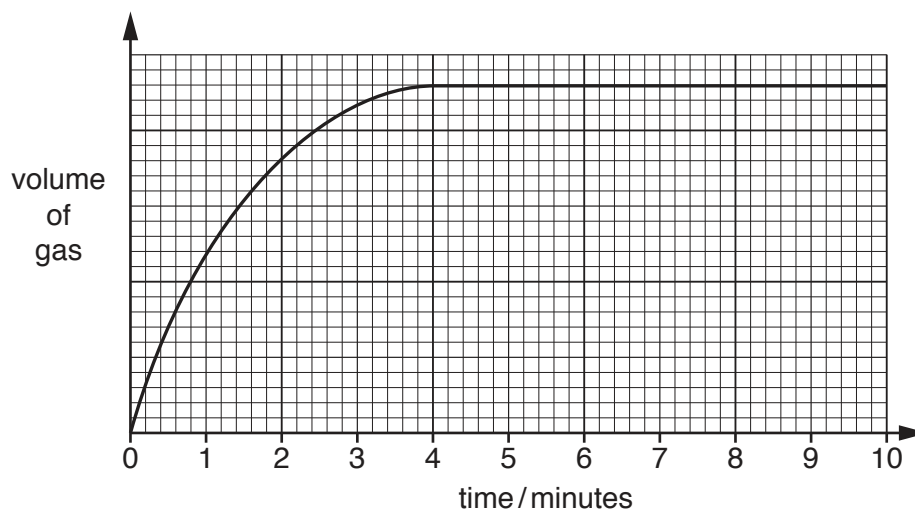

Fig. 5.2

Suggest why the reaction stops at 4 minutes.

.....
 [1]

- (c) The student repeats the experiment using the same mass of powdered copper(II) carbonate and the same volume of dilute sulfuric acid.

Suggest **one** change that the student can make to decrease the time taken for the reaction to stop.

..... [1]

- (d) The formula of sulfuric acid is H_2SO_4 .

- (i) State the number of different elements and the total number of atoms shown in this formula.

number of elements

number of atoms

[2]

- (ii) Describe a **chemical** test for sulfate ions and state the positive result.

test

.....

result

[2]

6 Fig. 6.1 shows a man standing in the sea on a sunny day.

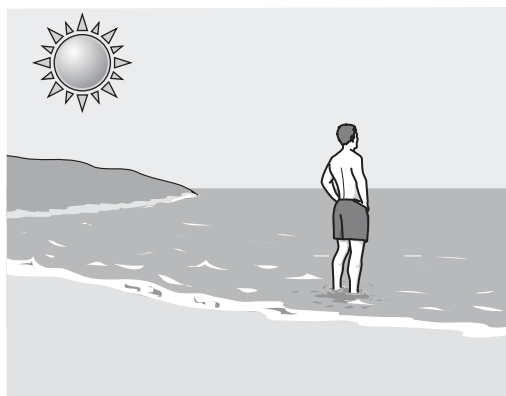

Fig. 6.1

(a) (i) The man says that his back is getting too hot in the Sun.

Describe how the thermal energy reaches his back from the Sun.

.....

 [2]

(ii) The temperature of the man's body is 37°C. The temperature of the sea water is 15°C.

Explain why the man says that the water feels cold to his feet.

.....

 [2]

(iii) The man walks out of the sea, and his wet feet slowly become dry. He says that his feet get colder as they dry.

Complete the sentences below that explain in terms of the movement of molecules why his feet get colder as they dry.

The water molecules escape from the surface of the water on his feet.

This means that the remaining water molecules have less

..... so the remaining water on his

feet is at a lower [2]

(b) Fig. 6.2 shows a man spear fishing. He sees a fish in the sea in front of him.

Fig. 6.2 shows part of a ray of light from the fish to the man's eye. He thinks the fish is in the position shown.

(i) On Fig. 6.2 continue the ray in the water to show where the fish really is.

Mark the real position of the fish with an X.

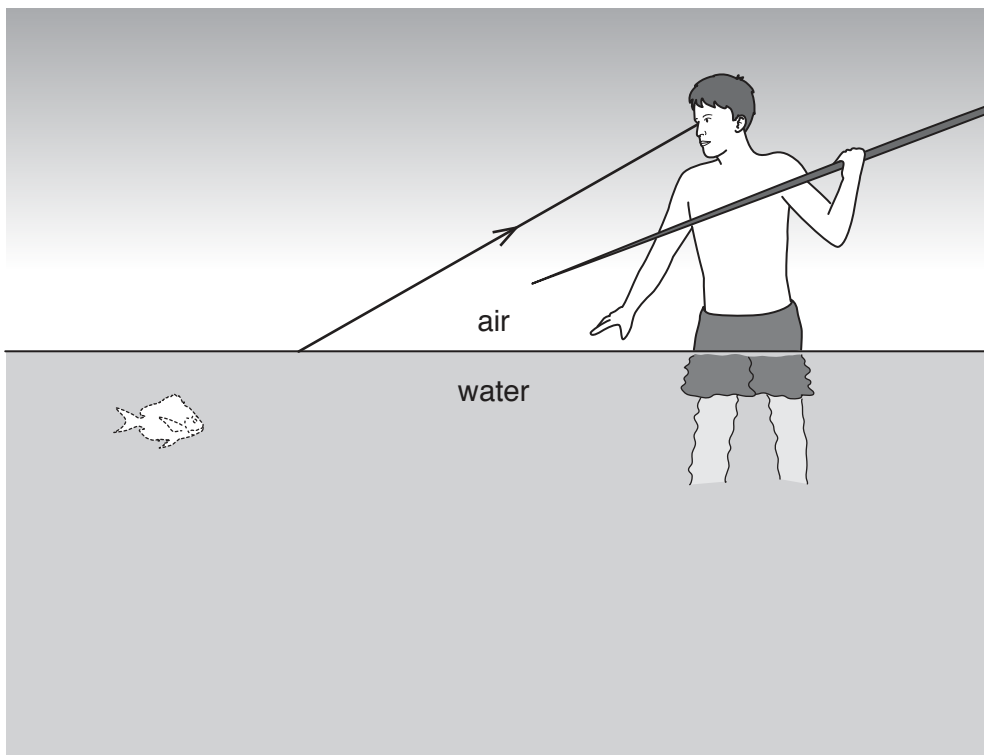

Fig. 6.2

[2]

(ii) State the name of this effect when light passes from air to water.

..... [1]

(c) The man cooks a fish in a microwave oven.

On Fig. 6.3 place microwaves in their correct position in the incomplete electromagnetic spectrum.

gamma rays			visible light			radio waves
------------	--	--	---------------	--	--	-------------

Fig. 6.3

[1]

- 7 Table 7.1 shows the mass of some of the contents of three foods in a 100 gram sample of each food.

Table 7.1

food	number of grams in the 100 gram food sample			
	fat	carbohydrate	protein	water
bread	7	60	13	20
egg	11	1	13	75
milk	3	5	3	89

- (a) State the **two** nutrient groups needed for a balanced diet which are missing from Table 7.1.
 and [2]

- (b) The energy for the body provided by one gram of each nutrient is shown below.

fat 37 kJ

carbohydrate 17 kJ

protein 17 kJ

A student cooked a meal using 100 grams of eggs.

Use the information contained in Table 7.1 to calculate the energy provided by the 100 grams of eggs.

Show your working.

energy provided = kJ [2]

(c) (i) The energy from food is released by respiration.

Complete the word equation for respiration.

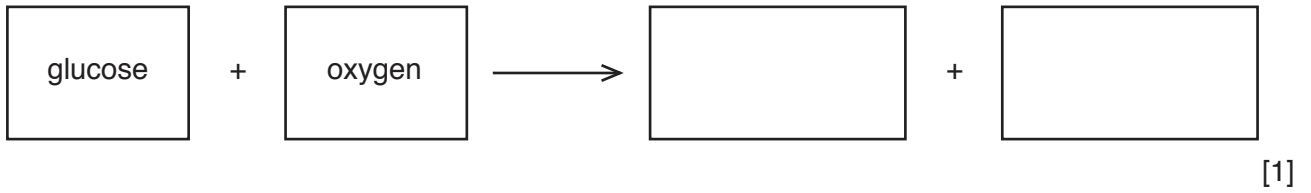

(ii) Describe how oxygen is transported by the blood.

.....
.....
..... [2]

(d) Fats, carbohydrates and proteins are made up from large molecules. They have to be broken down by chemical digestion into small molecules.

State the **three** areas of the alimentary canal where chemical digestion occurs.

1.
 2.
 3.
- [3]

8 Fig. 8.1 shows some uses of copper.

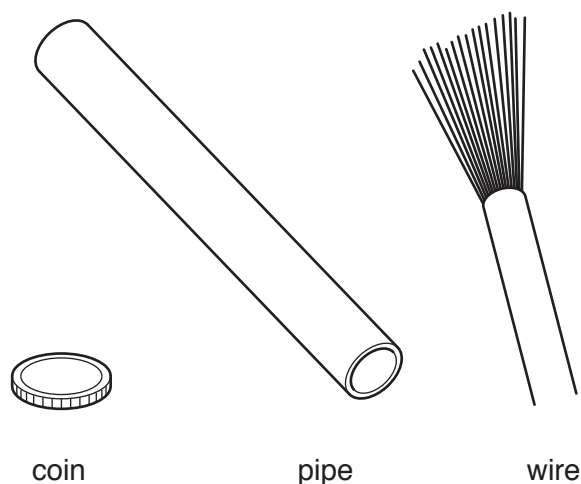
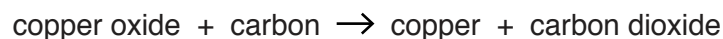

Fig. 8.1

Copper is extracted from copper oxide by reacting it with carbon.

The word equation for this reaction is:



(a) (i) Name the collection of metals in the Periodic Table which includes copper.

..... [1]

(ii) Use the word equation to identify the substance which is being reduced during the extraction of copper from copper oxide.

..... [1]

(iii) A hairdryer is powered through a cable containing copper wire.

Copper is a good conductor of electricity.

State **one other** property of copper that makes it a suitable material for use in a power cable.

..... [1]

(iv) Suggest **one** reason why copper, rather than iron, is used to make water pipes.

..... [1]

(v) Explain why copper alloys, rather than pure copper, are used to make coins.

..... [1]

(b) Three metals are placed into beakers of dilute hydrochloric acid, as shown in Fig. 8.2.

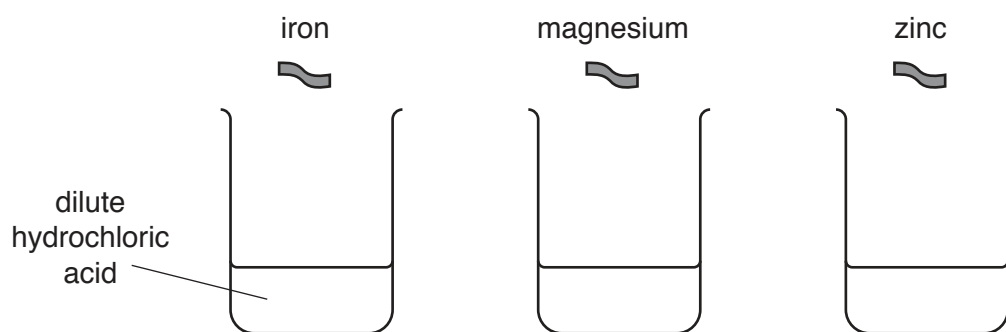

Fig. 8.2

State which of the three metals in Fig. 8.2 reacts most rapidly with dilute hydrochloric acid.

Name the gas which is made when this metal reacts with dilute hydrochloric acid.

metal

gas

[2]

- 9 Fig. 9.1 shows a simple test circuit for testing different materials to see how well they conduct electricity. The material being tested is connected between **X** and **Y**.

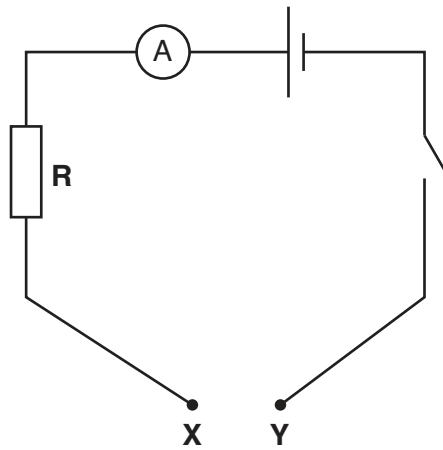

Fig. 9.1

- (a) (i) Name **two** materials other than copper that would be found to be good conductors when tested.

..... and [1]

- (ii) Name two materials that would be found to be poor conductors when tested.

..... and [1]

- (iii) State the name given to all materials that are poor conductors.

..... [1]

- (b) Explain why it is important to have a resistor, **R**, in the test circuit as well as the ammeter.

.....
 [1]

- (c) A piece of copper wire is connected between **X** and **Y**, and a voltmeter is connected in parallel to **R**.
- (i) On Fig. 9.1, using the correct circuit symbol, show how the voltmeter is connected to the circuit. [2]
- (ii) The ammeter reads 0.5A. The voltmeter reads 2V.

Calculate the resistance of **R**.

State the formula you use, show your working and give the unit of your answer.

formula

working

resistance = unit [3]

The Periodic Table of Elements

Group																	
I	II											III	IV	V	VI	VII	VIII
3 Li lithium 7	4 Be beryllium 9	Key atomic number atomic symbol name relative atomic mass										5 B boron 11	6 C carbon 12	7 N nitrogen 14	8 O oxygen 16	9 F fluorine 19	10 Ne neon 20
11 Na sodium 23	12 Mg magnesium 24											13 Al aluminium 27	14 Si silicon 28	15 P phosphorus 31	16 S sulfur 32	17 Cl chlorine 35.5	18 Ar argon 40
19 K potassium 39	20 Ca calcium 40	21 Sc scandium 45	22 Ti titanium 48	23 V vanadium 51	24 Cr chromium 52	25 Mn manganese 55	26 Fe iron 56	27 Co cobalt 59	28 Ni nickel 59	29 Cu copper 64	30 Zn zinc 65	31 Ga gallium 70	32 Ge germanium 73	33 As arsenic 75	34 Se selenium 79	35 Br bromine 80	36 Kr krypton 84
37 Rb rubidium 85	38 Sr strontium 88	39 Y yttrium 89	40 Zr zirconium 91	41 Nb niobium 93	42 Mo molybdenum 96	43 Tc technetium —	44 Ru ruthenium 101	45 Rh rhodium 103	46 Pd palladium 106	47 Ag silver 108	48 Cd cadmium 112	49 In indium 115	50 Sn tin 119	51 Sb antimony 122	52 Te tellurium 128	53 I iodine 127	54 Xe xenon 131
55 Cs caesium 133	56 Ba barium 137	57–71 lanthanoids	72 Hf hafnium 178	73 Ta tantalum 181	74 W tungsten 184	75 Re rhenium 186	76 Os osmium 190	77 Ir iridium 192	78 Pt platinum 195	79 Au gold 197	80 Hg mercury 201	81 Tl thallium 204	82 Pb lead 207	83 Bi bismuth 209	84 Po polonium —	85 At astatine —	86 Rn radon —
87 Fr francium —	88 Ra radium —	89–103 actinoids	104 Rf rutherfordium —	105 Db dubnium —	106 Sg seaborgium —	107 Bh bohrium —	108 Hs hassium —	109 Mt meitnerium —	110 Ds darmstadtium —	111 Rg roentgenium —	112 Cn copernicium —	114 Fl flerovium —	116 Lv livermorium —	—	—	—	—

57 La lanthanum 139	58 Ce cerium 140	59 Pr praseodymium 141	60 Nd neodymium 144	61 Pm promethium —	62 Sm samarium 150	63 Eu europium 152	64 Gd gadolinium 157	65 Tb terbium 159	66 Dy dysprosium 163	67 Ho holmium 165	68 Er erbium 167	69 Tm thulium 169	70 Yb ytterbium 173	71 Lu lutetium 175
89 Ac actinium —	90 Th thorium 232	91 Pa protactinium 231	92 U uranium 238	93 Np neptunium —	94 Pu plutonium —	95 Am americium —	96 Cm curium —	97 Bk berkelium —	98 Cf californium —	99 Es einsteinium —	100 Fm fermium —	101 Md mendelevium —	102 No nobelium —	103 Lr lawrencium —

The volume of one mole of any gas is 24 dm³ at room temperature and pressure (r.t.p.)